

FOR MESSRS : \_\_\_\_\_

**SPECIFICATION FOR APPROVAL**

(FOR LCD MNT 15~17" 4 LAMP APPLICATION PURPOSE)

TFT LCD BACKLIGHTING INVERTERPART NO. : FIF1742-45ABUYER'S PART NO.:

APPROVED	REFERENCE

( PLEASE RETURN ONE OF THESE TO US IMMEDIATELY WITH YOUR SIGNATURE FOR APPROVAL )

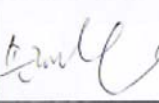
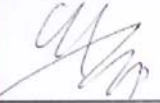
TESTED BY	CHECKED BY	APPROVED BY
		
J. S. Kim	J. H. Son	S. I. Lim

**CONTENTS OF SPECIFICATION**

INVERTER PART NO. : FIF1742-45A

<b>NO.</b>	<b>CONTENTS</b>	<b>PAGE</b>
1	Revision History	3 / 9
2	General Description	4 / 9
3	Features	4 / 9
4	Application	4 / 9
5	Absolute Maximum Rating	4 / 9
6	Electrical Characteristics	5 / 9
7	Functional Pin Description	6 / 9
8	Test Circuit	7 / 9
9	Mechanical Drawings	8 / 9
10	Quality Assurance Test	9 / 9



## 2.General Description

### SCOPE:

This DC-AC inverter was developed for 4 CCFL lamps of LCD backlight system.

## 3.Features

- On/Off control
- Liner output current adjustment
- Wide Dimming Range

## 4.Applications

- 15~17" 4 LAMP LCD Monitor / TV

## 5.Absolute maximum rating

- Input supply voltage : 11 ~ 13V
- Input current : 1.8A
- Output current(1 Lamps) : 6.4mA rms
- Ambient operating temperature : 0°C ~ 50°C
- Storage temperature : -25°C ~ 85°C
- Operating & Storage Humidity : 10% ~ 85%

## 6. Electrical Characteristics

▶ Analog Dimming

▶ Input Voltage(Vdc) : 11.0 ~13.0

No.	Items (Unit)	Sign.	Condition		Min.	Typ.	Max.
1	Input Current (A)	I <sub>in</sub>	V <sub>in</sub> =12V	CTRL=0V	1.65	1.8	1.95
				CTRL=5V	0.9	1.1	1.3
2	Output Current 1,2(mA)	I <sub>out1,2</sub>	V <sub>in</sub> =12V	CTRL=0V	5.8	6.4	7.0
				CTRL=5V	2.1	2.8	3.5
3	Output Current 3,4(mA)	I <sub>out3,4</sub>	V <sub>in</sub> =12V	CTRL=0V	5.8	6.4	7.0
				CTRL=5V	2.1	2.8	3.5
4	Lamp Frequency (kHz)	f	V <sub>in</sub> =12V	CTRL=5V	55	60	65
5	ON/OFF Control	ON	V <sub>in</sub> =12V, ON/OFF=5V		Normal Operation		
		OFF	V <sub>in</sub> =12V, ON/OFF=0V		Shunt-down (Lamp off)		
6	Dim Adjust (Lamp Current Control)	CTRL	CTRL=0V,Max Current		0.0 ~ 5.0 Volt.		
			CTRL=5V,Min Current				
7	Kick-Off Voltage(V <sub>rms</sub> )	V <sub>k-off</sub>	Kick-Off		MORE THAN 1100		

## 7. Functional Pin Description

### 7.1. Input Connector CN6 : 12505WR-12A00 (YEON-HO)

Pin No.	Symbol	Description
10,11,12	Vin	Input Voltage : 12V $\pm$ 1V
1,3.5.6.8.9	GND	GND
2	CTRL	Dim Adjust, Apply 0V ~ 5Vdc to Control Lamp Current 0 V : 6.4mA, 5V : 2.8mA (Each Lamp)
4	ON / OFF	Power System Return ( 5V:ON, 0V:OFF )

### 7.2. Output Connector CN2,CN3,CN4,CN5 : SMO2B-BHS-1-TB (JST, YHON-HO, MOLEX)

Pin No.	Symbol	Description
1	Lamp H1	High Voltage connection to high side of lamp.
2	Lamp L1	Low Voltage connection to low side of lamp.

### 8.Test Circuit

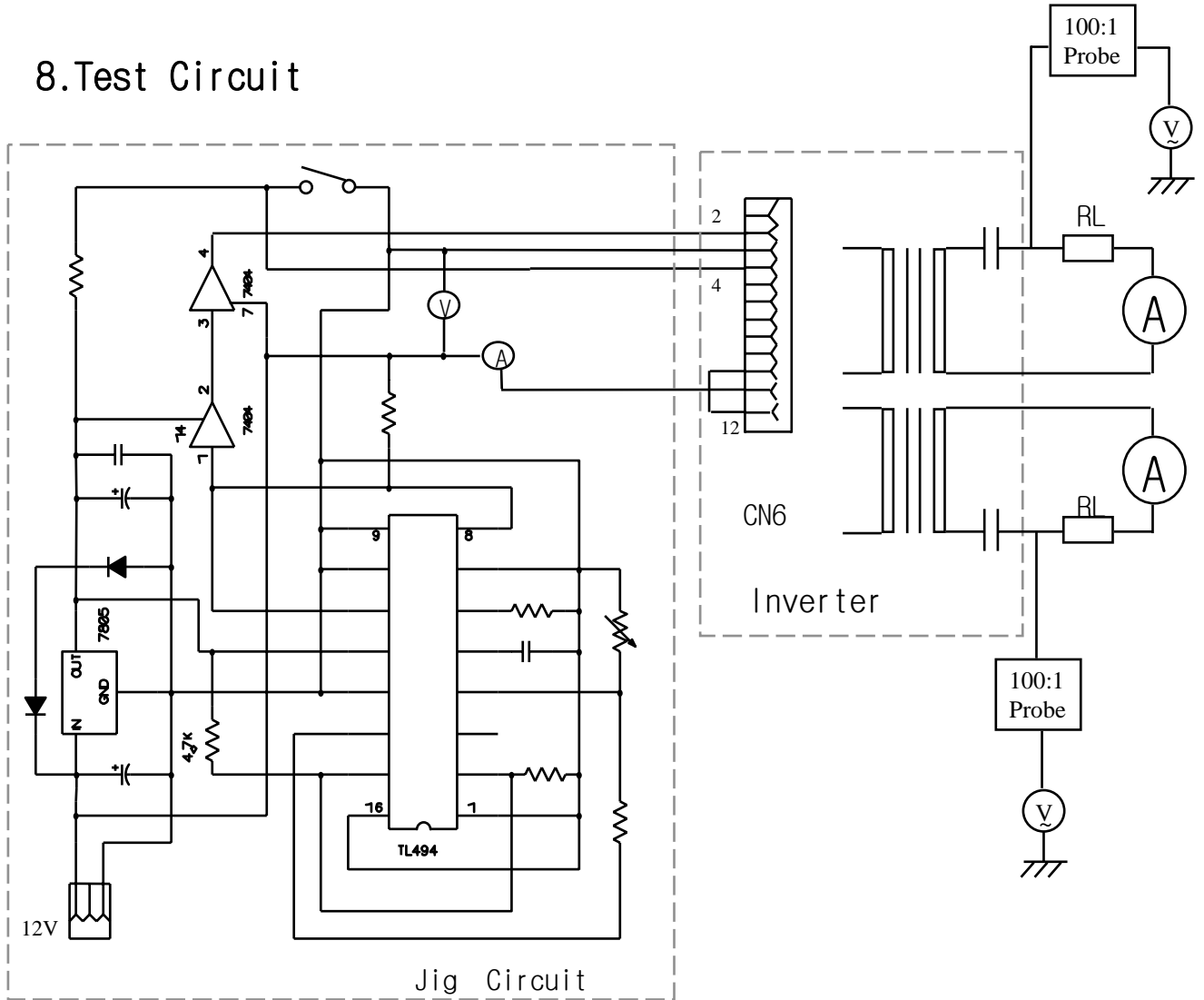

- \* Input Volt Meter : Fluke 45
- \* Input Current Meter : Fluke 45
- \* Output Current Meter : Fluke 45(Yokogawa P2016-1)

# 9.Mechanical Drawings

## 9-1.P.W.B

\*. Unit : mm

\*.Tolerance : ± 0.2mm

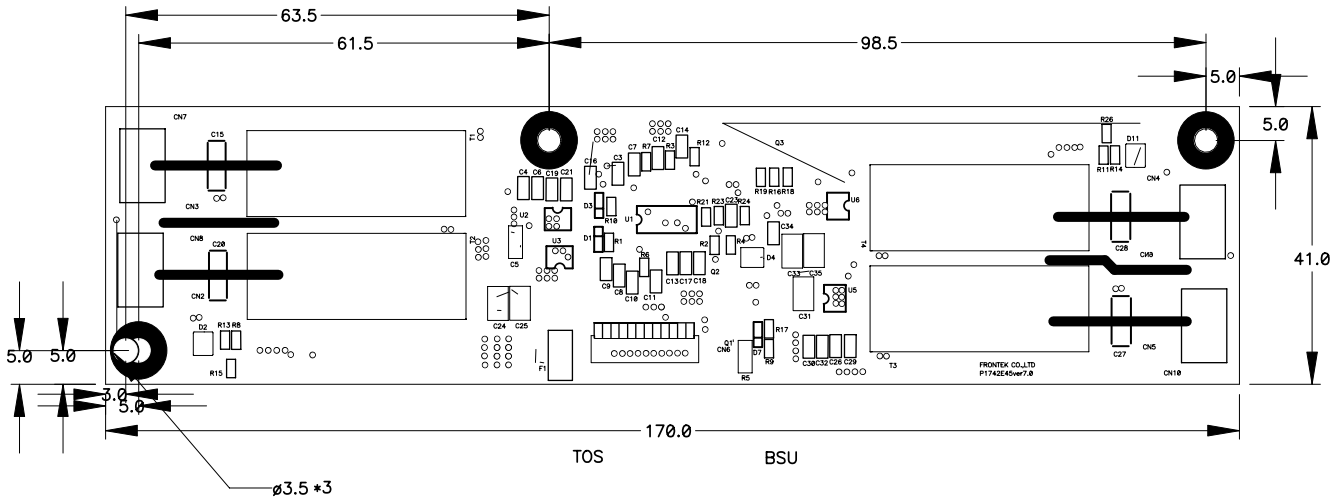

## 9-2.Trans & Insulator

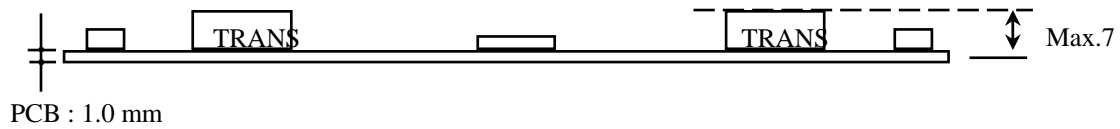

## 9-3.Marking

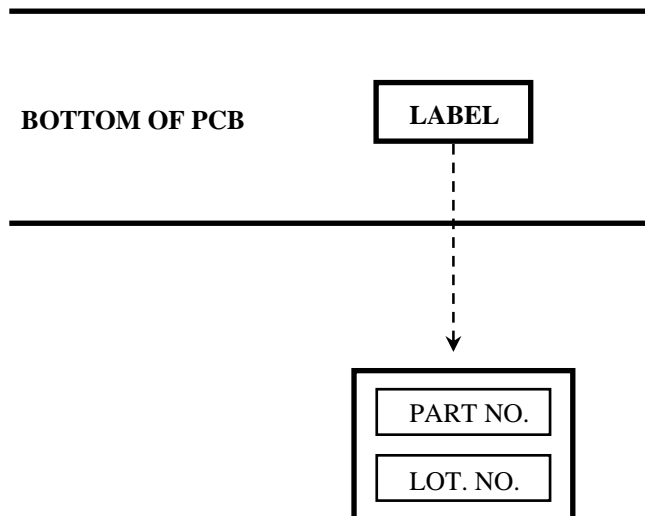

\*.PART NO. : FIF1742-45A

\*. LOT NO : FA ○○○○○○

YEAR MONTH DAY

## 10. Quality Assurance Test

NO.	ITEMS	TEST CONDISIONS	Numbers of Samples	NOTE
0	Electrical Characteristics & Appearance test	Electrical Characteristics & Mechanical size on approval sheet	21 EA	
1	High temperature Operation Test	50°C, Vin = 13.2V, Ctrl = 0V, 500Hr	3 EA	
2	Low temperature Operation Test	0°C, Vin = 13.2V, Ctrl = 0V, 240Hr	3 EA	
3	High temperature Storage Test	80°C, 240Hr	3 EA	
4	Low temperature Storage Test	-20°C, 240Hr	3 EA	
5	High temperature & High Humidity Storage Test	40°C, 95%RH, 240Hr	3 EA	
6	Heat Shock Test	-20°C(0.5Hr) + 80°C(0.5Hr) 20 Cycle	3 EA	
7	Power On/Off test	Vin = 13.2V, On/Off = 1000 Cycle	3 EA	On Time(2 sec ) + Off Time(2 Sec)